



请承认书

Version No.: V2.1

常州昊翔电子有限公司
Changzhou HaoXiang Electronic Co., LTD

客户名称

CUSTOMER NAMER : _____

产品名称

COMMODITY : PIEZO BUZZER

产品型号

MODEL NO : TDA-12240PA-2

客户料号

PART NO : _____

审核

秦皓

主办

潘莲 Aug.6,2018

客户承认栏

承认

拒收

常州昊翔电子有限公司

常州声翔电子有限公司

常州公司:

江苏省常州市戚区潞城镇富民路 286 号

TEL:86-519-8363089 13585451311

FAX:86-519-88353844

E-mail: sales@tda-buzzer.com sales2@tda-buzzer.com

南通工厂:

江苏如皋市郭元镇工业园辰翔工业区

TEL:86-513-87910588 871919168

FAX:86-513-87915598

A. SCOPE

This specification applies piezo buzzer, **TDA-12240PA-2**

B. SPECIFICATION

No.	Item	Unit	Specification	Condition
1	Oscillation Frequency	Hz	4000	square wave
2	Operating Voltage	Vp-p	20 max	
3	Current Consumption	mA	MAX. 3	at 5Vp-p
4	Sound Pressure Level	dB	MIN. 70 TYP. 85dB	at 10cm 5Vp-p 4000Hz
5	Operating Temperature	°C	-20 ~ +70	
6	Storage Temperature	°C	-30 ~ +80	
7	Dimension	mm	Ø12.8xH7.5	See appearance drawing
8	Weight (MAX)	gram	1.5	
9	Housing Material		PBT(Black)	
10	Leading Pin		Tin Plated Brass(Sn)	See appearance drawing
11	Environmental Protection Regulation		RoHS	

C. APPEARANCE DRAWING

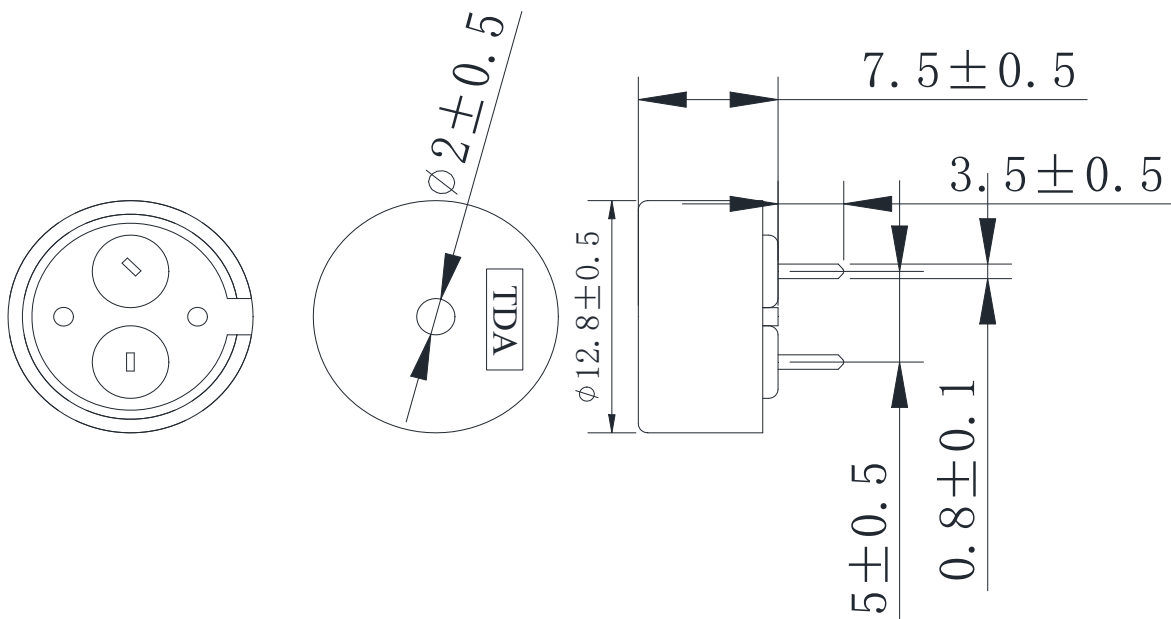

Unit:mm Tolerance : ± 0.5 mm

D. RECOMMEND DIRVING CIRCUIT

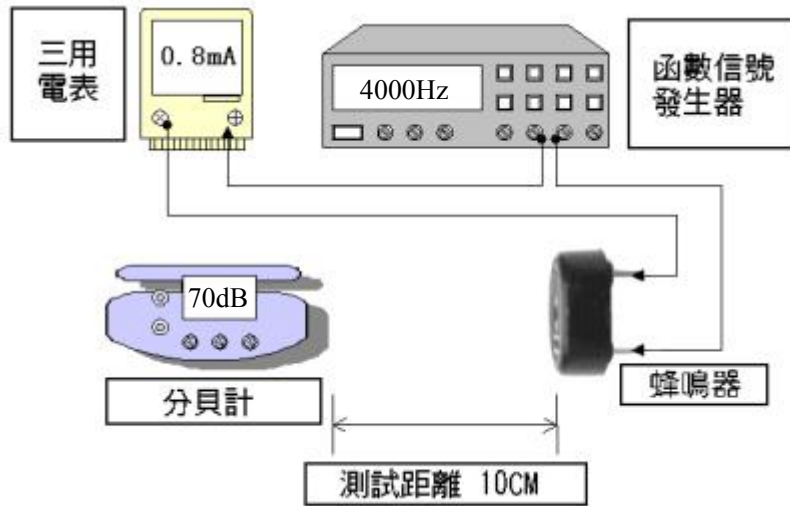

E. FREQUENCY CURVE

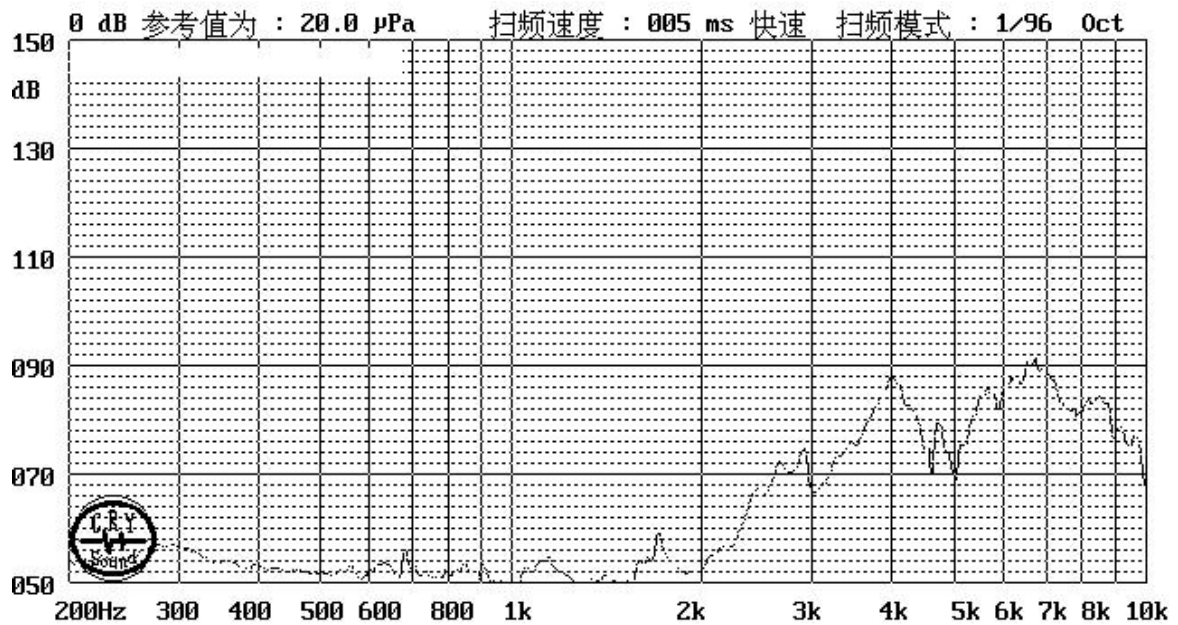

F. MECHANICAL CHARACTERISTICS

NO	Item	Test Condition	Evaluation standard
1	Solderability	Stripped wires of lead wires are immersed in rosin for 5 seconds and then immersed in solder bath of $270\pm 5^{\circ}\text{C}$ for 3 ± 0.5 seconds.	90%min stripped wires shall be wet with solder.(except the edge of terminal)
2	Soldering Heat Resistance	Stripped wires are immersed up to 1.5mm from insulation in solder bath of $300\pm 5^{\circ}\text{C}$ for ± 0.5 seconds or $260\pm 5^{\circ}\text{C}$ for 10 ± 1 seconds.	No interference in operation
3	Terminal Strength Pulling	The force 10 ± 1 seconds of 9.8N is applied to each terminal in axial direction	No damage and cutting off
4	Vibration	Buzzer shall be measured after being applied vibration of 1.5mm with 10 to 55Hz band of vibration frequency to each of 3 per-pendicular directions for 2 hours.	The value of oscillation frequency and current consumption should be in $\pm 10\%$ compared with initial ones.
5	Drop test	Dropped naturally from 80cm height onto the surface of 40mm thick wooden board of 3 directions for 1times.	The SPL should be in $\pm 10\text{dB}$ compared with initial one.

G. ENVIRONMENT TEST

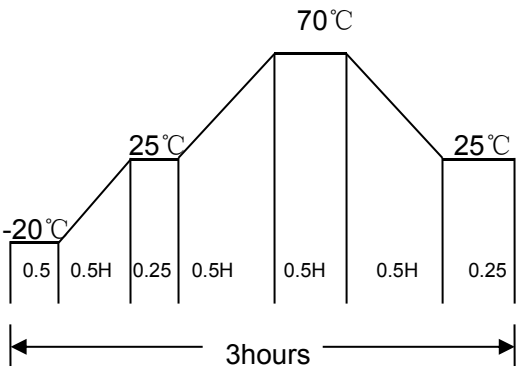
NO	Item	Test Condition	Evaluation standard
1	High temp. test	After being placed in a chamber at 80°C for 96 hours	Being placed for 4 hours at 25°C, buzzer shall be measured. The value of oscillation frequency and current consumption should be in ±10% compared with initial one. The SPL should be in ±10dB compared with initial one.
2	Low temp. test	After being placed in a chamber at -30°C for 96 hours	
3	Humidity test	After being placed in a chamber at 40°C and 85±5% relative humidity for 96 hours	
4	Temp. cycle test	<p>The part shall be subjected to 5 cycles. One cycle shall be consist of:</p> 	

H. RELIABILITY TEST

NO	Item	Test condition	Evaluation standard
1	Operating life test	<ol style="list-style-type: none"> Continuous life test 96 hours continuous operation at 70°C with maximum rated voltage applied. Intermittent life test A duty cycle of 1 minute on, 5 minutes off, a minimum of 1000 times at room temp. (25±2°C) and maximum rated voltage applied 	Being placed for 4 hours at 25°C, buzzer shall be measured. The value of oscillation frequency and current consumption should be in ±10% compared with initial one. The SPL should be in ±10dB compared with initial one.

TEST CONDITION

Standard Test Condition : a) Temperature : +5 ~ +35°C b) Humidity : 45-85% c) Pressure : 860-1060mbar

Judgment Test Condition: a) Temperature : +25±2°C b) Humidity : 60-70% c) Pressure : 860-1060mbar

I. PACKING STANDARD

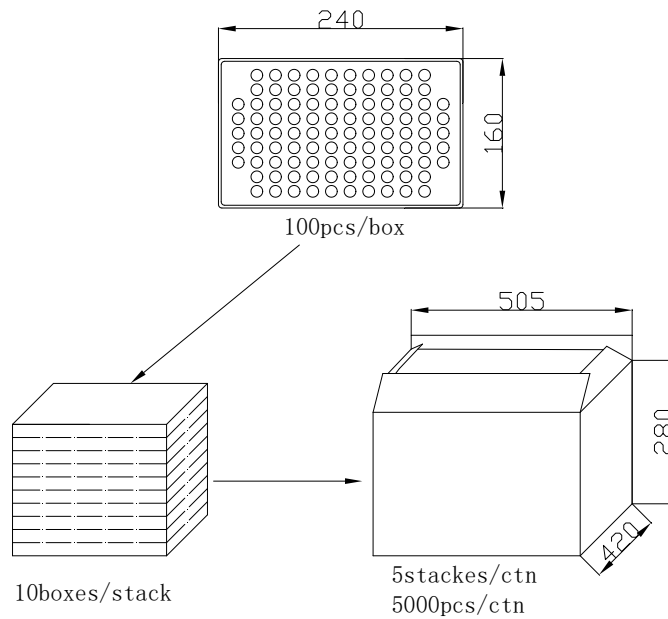

J. NOTE CAUTIONS

- a. Can not be applied DC bias voltage and a sounding body or pronunciation elements, otherwise its insulation resistance will decrease and the use of performance degradation.
- b. Can not be imposed over pronunciation body or pronunciation components allows the use of voltage range of the voltage on the.
- c. Please pay attention in welding process, don't let soldering flux invasion into the sound chamber , otherwise flux can cause defect conduction.
- d. Use should handle with care, avoiding direct pressure contact, or inadvertently falling down, to prevent the occurrence of fault, or the generation characteristics of abnormal movements.

K. NOTICE ON PRODUCT STORAGE

- a. Please store the products in room where the temperature / humidity is stable. And avoid such places where there are large temperature changes. Please store the products under the following conditions :
Temperature : -10 to +40 (degree C)
Humidity : 15 to 85% R.H.
- b. Expire date (Shelf life) of the products is 6 months after delivery under the conditions of a sealed and an unopened package. Please use the products within 6 months after delivery.If you store the products for a long time (more than 6months), use carefully because the products may be degraded in the solder-ability and/or rusty. Please confirm solder-ability and characteristics for the products regularly.
- c. Please use the products immediately after the package is opened, because the characteristics may be reduced in quality, and/or be degraded in the solder-ability due to storage under the poor condition.

